

Span-Lok™ *hp*, Curved Span-Lok™, & SpanSeam

MANUFACTURER • AEP SPAN

www.aepspan.com • info@aepspan.com

800-733-4955



Span-Lok *hp*, Curved Span-Lok, & SpanSeam are performance-rated architectural standing seam metal roof systems. The mechanically seamed rib provides aesthetic appeal and weather tightness, for a roofing system that can be used in a wide variety of new construction or retrofit applications. The system may be installed to span between supports or over solid substrates.

This Guide Specification is to be used to develop an office master specification or specifications for a project. Edit this guide specification to meet project requirements. Coordinate with other specification sections as required.

Document Coordination: Select framing, substrate, insulation, underlayment, flashing, trim, and clips, and indicate in Drawings; details are available on AEP Span's web site. For projects using several profiles or finishes, schedule panels in this section or in Drawings. Edit "Architect" to reflect the title of the design professional of record.

This document is available in word processing format at www.aepspan.com.

SECTION 07 41 13 – METAL ROOF PANELS

PART 1 - GENERAL

1.1 SUMMARY

- A. Section Includes: Prefinished, prefabricated structural standing seam roof system with continuous interlocking field formed seams.

Edit list of related sections for project requirements. Section numbers and titles are those recommended in CSI MasterFormat; revise numbers and titles to reflect actual sections in Project Manual.

- B. Related Requirements:
1. Section 05 10 00: Structural Metal Framing.
 2. Section 05 40 00: Cold-Formed Metal Framing.
 3. Section 05 50 00: Metal Fabrications.
 4. Section 07 62 00: Sheet Metal Flashing and Trim
 5. Section 07 92 00: Joint Sealants.

1.2 REFERENCES

- A. Reference Standards:
1. ASCE 7: Minimum Design Loads for Buildings and Other Structures.
 2. ASTM A653: Steel Sheet, Zinc Coated (Galvanized) or Zinc Iron Alloy Coated (Galvannealed) by the Hot Dip Process.
 3. ASTM A792: Steel Sheet, 55 % Aluminum Zinc Alloy Coated by the Hot Dip Process.
 4. ASTM C1371: Determination of Emittance of Materials Near Room Temperature Using Portable Emissometers.
 5. ASTM C1549: Determination of Solar Reflectance Near Ambient Temperature Using a Portable Solar Reflectometer.
 6. ASTM D523: Specular Gloss.

7. ASTM E1680: Rate of Air Leakage Through Exterior Metal Roof Panel Systems
8. ASTM E1592: Structural Performance of Sheet Metal Roof and Siding Systems by Uniform Static Air Pressure Difference.
9. ASTM E1646: Water Penetration of Exterior Metal Roof Panel Systems by Uniform Static Air Pressure Difference.
10. ASTM E1918: Measuring Solar Reflectance of Horizontal and Low Sloped Surfaces in the Field.
11. ASTM E1980: Calculating Solar Reflectance Index of Horizontal and Low Sloped Opaque Surfaces.
12. ASTM E2140: Weather Penetration of Metal Roof Panel Systems by Static Water Pressure Head.
13. CRRC-1 Method #1: Measuring Solar Reflectance of a Flat, Opaque, and Heterogeneous Surface Using a Portable Solar Reflectometer.
14. FM Approvals Standard 4471: Class 1 Panel Roofs.
15. SMACNA Architectural Sheet Metal Manual.
16. UL 580: Standard for Tests for Uplift Resistance of Roof Assemblies
17. US Environmental Protection Agency: Energy Star Reflective Roof Products
18. US Green Building Council (USGBC): Leadership in Energy and Environmental Design (LEED)

1.3 SUBMITTALS

- A. Product Data.
- B. Shop Drawings:
 1. Indicate thickness and dimensions of parts, fastenings and anchoring methods, details and locations of joints, transitions and other provisions necessary for thermal expansion and contraction.
 2. Indicate locations of field- and factory-applied sealant.
- C. Samples:
 1. Submit two samples, 12 inches long by full panel width, showing proposed metal thickness and seam profile.
 2. Submit standard color samples of metal for Architect's selection.
- D. Manufacturer Qualifications.
- E. Installer Qualifications: Submit list of completed projects, with names and contact information for architects and contractors.
- F. Test Reports: Indicating compliance of products with project requirements.

Delete LEED Submittals paragraph and subparagraph below if Recycled Content credit is not required for project. Credit is based on LEED 2009 NC, Schools, and CS rating systems.

Span-Lok roof system may support additional credits that do not require LEED submittals demonstrating compliance of metal panels. One such credit is LEED Credit EA Credit 1 – Optimize Energy Performance: cool-pigment finishes reduce heat gain, so may reduce overall building energy use.

- G. LEED Submittals:
 1. LEED Credit SS 7.2 – Heat Island Effect – Roof: Product data indicating Solar Reflectance Index (SRI) of roof panels.
 2. LEED Credit MR 4 – Recycled Content: Product data indicating percentage by weight of post-consumer and post-industrial recycled content for products having recycled content. Include statement indicating costs for each product having recycled content.

- H. Warranty Documentation.
- I. Insurance Documentation.

1.4 QUALITY ASSURANCE

- A. Manufacturer Qualifications:
 - 1. Ten years' experience, minimum, in factory fabrication of metal panels.
 - 2. Manufacturer shall carry \$2,000,000 liability insurance, minimum, for metal panel system.
- B. Installer Qualifications:
 - 1. Three years' experience, minimum, in application of metal roof or wall panels.
 - 2. Five satisfactory projects with metal panel work of similar scope and complexity to Work of this Project.
 - 3. Installer must be approved by manufacturer in writing prior to bid. Approval document must be included with project bid.
- C. Testing Agency Qualifications: Agency compliant with ISO/IEC Standard 17025, or an accredited independent agency recognized by the International Laboratory Accreditation Cooperation Mutual Recognition Arrangement or ANSI.

Generally delete requirement for mock-ups. Two instances where metal panels may be required in mock-ups are shown below; retain applicable requirements and edit to suit Project.

- D. Mock-Ups:
 - 1. Visual Mock-Up: Construct mock-up, 10 by 10 feet or larger as required to show at least two pattern repeats, and in same orientation as **[entrance facade] [facade designated by Architect] <Insert location>**.
 - 2. Performance Mock-Up: Construct metal panel system as required for Performance Mock-Up specified in **[Section 01 43 39 "Mock-Ups"] <Insert section>**.

1.5 DELIVERY, STORAGE, AND HANDLING

- A. Storage and Handling Requirements:
 - 1. Keep panels and accessory items dry.
 - 2. Protect against damage and discoloration.
 - 3. Handle panels with non-marring slings.
 - 4. Support panels to prevent permanent deformation.
 - 5. Store panels above ground, with one end elevated for drainage.
 - 6. Protect panels against standing water and condensation between adjacent surfaces.
 - 7. If panels become wet, immediately separate sheets, wipe dry with clean cloth, and keep sheets separate for air-drying.
 - 8. Painted panels shall be shipped with protective plastic sheeting or a strippable film coating between panels. Remove strippable film coating prior to installation. Do not allow strippable film coating to remain on panels in extreme heat, cold, or direct sunlight or other UV source.
 - 9. Do not allow panels to contact treated lumber.

1.6 WARRANTY

For projects less than 1320 feet (1/4 mile) from salt water or industrial or other corrosive applications, consult your AEP Span Representative. A high-build primer of 0.8-1.2 mils or other coating system may be recommended and warranty developed specifically for job site conditions

- A. Manufacturer's Warranty: Manufacturer's standard 25-year performance warranty, stating the following:
 - 1. Architectural fluorocarbon finish:
 - a. Will be free of fading or color change in excess of 5 Hunter delta-E units as determined by ASTM D2244-02.
 - b. Will not chalk in excess of numerical rating of 8 when measured in accordance with standard procedures specified in ASTM D4214-98 method D659.
 - c. Will not peel, crack, chip, or delaminate.
 - 2. Metal substrate will not rupture, fail structurally, or perforate.
- B. Installer's Warranty: Warrant panels, flashings, sealants, fasteners and accessories against defective materials and/or workmanship, covering repairs required to maintain roof panels watertight and weatherproof with normal usage for two years following Project Substantial Completion date.
 - 1. Furnish written warranty, signed by installer.
- C. Weathertight Performance Warranty: Manufacturer's standard warranty in which manufacturer agrees to repair or replace metal roof panel assemblies that fail to remain weather tight within specified warranty period.
 - 1. Contact AEP Span for Weathertight Warranty information and requirements.

PART 2 - PRODUCTS

2.1 SYSTEM DESCRIPTION

This guide specification demonstrates how to specify Span-Lok hp, Curved Span-Lok, and SpanSeam by AEP Span. If a competitive specification is required, add additional manufacturers and retain the option in the paragraph below.

Select one or more AEP Span profiles according to visual and performance criteria. Both Span-Lok hp and Curved Span-Lok are field-seamed with 90-degree seams; SpanSeam is field seamed with 180-degree seams. Span-Lok hp is Factory Mutual rated 1-90 and 1-120, and is available in both 12-inch and 16-inch widths. Curved Span-Lok is machine curved in the factory or the field. For more selection assistance, visit www.aepspan.com.

- A. Products: Provide **[one of]**the following:
 - 1. AEP Span, a Division of ASC Profiles, Inc.; **[Span-Lok hp][Curved Span-Lok] [SpanSeam]**.

Select one of two options below. If listing multiple manufacturers above, chose first option. If choosing second option, edit section number and title to match actual Division 01 section where substitutions are controlled.

- B. Substitution Limitations: **[Substitutions will not be considered.] [Substitutions will be considered in accordance with Section 01 25 00 "Substitution Procedures".]**
- C. Performance Criteria

AEP Span tests its panels for wind uplift using UL 580 and ASTM E1592. In addition, Span-Lok hp is rated by FM Approvals.

Generally, do not specify both performance and panel thickness. If using performance method, consult structural engineer and edit below. For panel thickness method, see wind resistance tables at www.aepspan.com, delete paragraph below, and retain a thickness in "Panel" article.

1. Wind Uplift: **[Class 90 per UL 580] [As required by [ASCE 7] <Insert governing code>] <Insert required load>**.
 - a. Panel system shall be ASTM E1592 tested under the supervision of an ANSI or ISO/IEC accredited laboratory and the laboratory shall issue the test report.
 - b. Deflection Limits: Withstand wind loads with deflections no greater than **[1/180] <Insert ratio>** of the span.

Retain below if FM Approval rating is a project requirement and if SpanLok hp is specified. Choose the required rating class.

2. FM Rating: **[Class 1-90] [Class 1-120]** according to FM Approvals Standard 4471.
3. Air Infiltration: Tested in accordance with ASTM E1680.
 - a. 0.022 cfm per linear foot of joint at static test pressure differential of 12.00 psf.

Coordinate performance requirements with specified panels. Retain paragraph above for Curved Span-Lok and Span-Lok hp. Retain paragraph below for SpanSeam.

- b. 0.002 cfm per linear foot of joint at static test pressure differential of 12.00 psf.
4. Water Infiltration Under Static Pressure: Tested with sidelap sealant per ASTM E1646.
 - a. No leakage through panel joints at 15.00 psf.

Coordinate performance requirements with specified panels. Retain paragraph above for Curved Span-Lok and Span-Lok hp. Retain paragraph below for SpanSeam.

- b. No leakage through panel joints at 20.00 psf.

AEP Span has tested Span-Lok hp and SpanSeam panels for water penetration using ASTM E2140, which is a rigorous evaluation for metal roof panels. Most manufacturers only test water infiltration using ASTM E1646.

5. Water Penetration: No leakage through panel sideseams and endlaps after six hours when tested according to ASTM E2140 at a static water pressure head of 6.00 inches.
6. Thermal Movements: Accommodate thermal movement without buckling, joint opening, overstressing components, failure of connections, or other detrimental effects, through the following temperature changes:
 - a. 120 degrees F, ambient.
 - b. 180 degrees F, material surface.

D. Sustainability Characteristics:

AEP Span panels, in their standard sheet steel, contain approximately 25.5 percent post-consumer recycled content and 6.8 percent pre-consumer recycled content, for a total 28.9 percent recycled content as calculated for this LEED credit. Higher percentages are available if specified.

1. Recycled Content: **[28.9] [50] [75]** percent post-consumer recycled content[, **calculated according to LEED Credit MR 4**].
2. Energy Performance:

If "cool roof" reflective pigments are required, retain one of the three subparagraphs below. Check performance by color: some colors perform better than examples given.

- a. Provide Energy Star qualified product for slope indicated in Drawings.

LEED Credit SS 7.2 is for SRI of 29 or higher for roofing with pitch 2:12 or steeper and SRI of 78 or higher for roofing of lower slope. In subparagraph below, first value is for DuraTech 5000 and DuraTech mx coatings; second value is for DuraTech Dimensional Prints.

- b. Solar reflective index (SRI): Not less than [29][22]<Insert requirement> per ASTM E1980.
- c. Reflectance and Emissivity:
 - 1) Solar Reflectance: Not less than [0.25]<Insert requirement> per ASTM test methods C1549 or E1918, or CRRC-1 Method #1.
 - 2) Thermal Emissivity: Not less than [0.75]<Insert requirement> per ASTM C1371.
- 3. Shipping Distance: Provide panels manufactured at the following factory:

If locally manufactured materials are a project requirement, select factory closer to Project site,

- a. Fontana, California 92335
- b. Tacoma, Washington 98421

If project is subject to Federal Buy American provisions, retain paragraph below. AEP Span products comply with requirement.

- E. Manufacturing Characteristics: Provide panels complying with provisions of Buy American Act 41 U.S. C 10a - 10d.

2.2 PANELS

These products are suitable for slopes as low as 1/4:12. Please consult an AEP Span representative for slope design restrictions.

- A. Panels: AEP Span, a Division of ASC Profiles, Inc.; Preformed Metal Standing Seam Roofing – Span-Lok hp (SL2HP212, SL2HP216), Curved Span-Lok (SL2C216), SpanSeam (SPS2216), and.
 - 1. Material: Steel conforming to ASTM A792.

Select gauge according to AEP Span's performance tables, required span, and applicable loads. 24 and 22 gauge panels are standard.

- a. **[24 Gauge][22 Gauge]**: Yield strength 50,000 psi; with aluminum-zinc alloy coating conforming to ASTM A792, Class AZ50.

If panels are specified by performance, retain subparagraph below and delete subparagraph above.

- b. Thickness and yield strength as required for performance indicated; with aluminum-zinc alloy coating conforming to ASTM A792, Class AZ50 For projects with multiple profiles or varied combinations of profiles, rib patterns and finishes, show on Drawings.
- 2. Panel Width and Pattern: **[As Scheduled.]**

Only Span-Lok hp is available 12 inches wide.

- a. 12-inch panel width, **[flat pan] [with striated pattern]**.
- b. 16-inch panel width, **[flat pan] [with 2 pencil ribs spaced 6 inches on center] [with striated pattern]**.

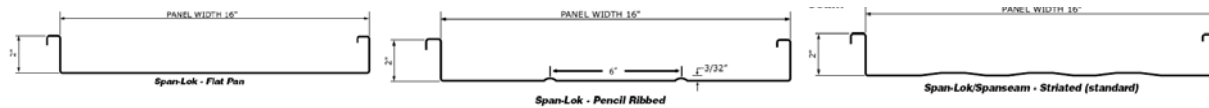

Panel leg views - after seaming

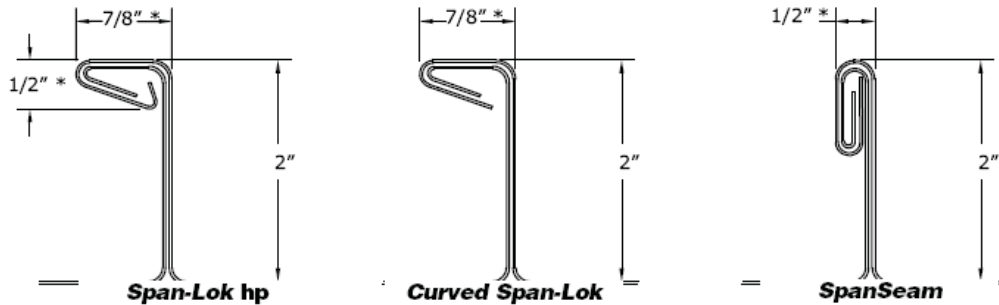

* Note: Dimensions Approximate

3. Panel Seam Height: **[2 inches]**.
* *Dimensions are approximate.

If multiple finishes are required, retain applicable finishes.

4. Panel Finish: Provide primer and top finish coat on exposed faces; provide primer and backer coat on concealed faces of panels.

Choose one or more of the following exterior finishes.

- a. DuraTech® 5000: Polyvinylidene Fluoride, full 70 percent Kynar 500® or Hylar 5000®, consisting of a baked-on 0.15-0.20 mil corrosion resistant primer and a baked-on 0.70-0.80 mil finish coat with a specular gloss of 8 to 15 when tested in accordance with ASTM D523 at 60 degrees.
- b. DuraTech® mx metallic finish, consisting of a baked-on primer 0.15-0.2 mil and a baked-on Polyvinylidene Fluoride finish coat 0.70-0.80 mil with a specular gloss of 20 to 35 when tested in accordance with ASTM D523 at 60 degrees.

Zincalume Plus is a thin, clear acrylic topcoat, recommended for uniform weathering of unpainted Zincalume panels.

- c. Zincalume® Plus protective coating for unpainted aluminum-zinc alloy coating.
- d. DuraTech® Dimensional Prints: Polyvinylidene Fluoride, full 70 percent Kynar 500 or Hylar 5000, consisting of a baked-on corrosion resistant primer and a baked-on finish coat with a dry film thickness of 1.10 to 1.40 mil and specular gloss of 25 to 35 when tested in accordance with ASTM D523 at 60 degrees.

Custom colors are available on orders of 3,000 linear feet or more. Consult an AEP Span representative for additional information.

- e. Panel Color: **[As scheduled.]****[As selected from manufacturer's full range.]**<Insert color.>

Factory-applied seam sealant is not available on Curved Span-Lok.

5. Seam Sealant: Factory apply high-grade butyl mastic sealant within the confines of panel's female leg, designed to seal against adjacent male panel leg.

2.3 FRAMING AND SUBSTRATES

Edit framing and substrates to reflect Project requirements. Coordinate section numbers and titles.

- A. Secondary Framing: See Section 05 40 00 "Cold-Formed Metal Framing".
- B. Sheathing: See Section 06 16 00 "Sheathing".
- C. Roofing Underlayment:
 - 1. Roofing Felt: <Insert Requirements>
 - 2. Self-Adhering Sheet Underlayment: <Insert Requirements>
 - 3. Slip Sheet: <Insert Requirements>

2.4 CLIPS AND FASTENERS

Clip selection to be determined based upon panel framing, substrate and attachment requirements. See AEP Span installation guidelines for clip types at www.aepspan.com.

- A. Clips: Provide clip designed to allow panels to thermally expand and contract. Clip shall incorporate a self-centering feature to allow 1 inch of movement in both directions along panel length. Clip type shall be selected to meet positive and negative pressures as specified.
 - 1. Sealant: Factory-installed sealant to provide continuity of seal at clip locations.

Retain bearing plate if required for compressible substrates such as rigid insulation.

- B. Bearing Plate: Designed with tabs to attached clip base to bearing plate on the ground, prior to installation.

See Metal Construction Association Technical Bulletin "Fastener Selection". Usually retain first option; retain second option if UL Class 90 is required.

- A. Fasteners: **[As recommended by manufacturer for performance indicated.][Manufacturer's standard #12 - 14 by 1 1/4 inch long self-drilling, hex head drive screws for metal; noncorrosive base material.]**

2.5 INSULATION

Edit Insulation article to reflect insulation required for roof assembly.

- A. Rigid Insulation: **[See Section 07 22 00 "Roof and Deck Insulation".]<Insert requirements.>**
 - 1. Thermal Spacer Blocks: As recommended by roofing manufacturer.
- B. Fiberglass Insulation: **[See Section 07 21 00 "Thermal Insulation".]<Insert requirements.>**
- C. Acoustic Insulation: **[See Section 09 81 00 "Acoustic Insulation".]<Insert requirements.>**

2.6 ACCESSORIES

- A. Trims and Flashings: Material, metal thickness, and finish to match panels. Profiles indicated in Drawings.
 - 1. Provide manufacturer's standard accessories and other items essential to completeness of standing seam roof installation.

- B. Panel Penetration Flashings: As recommended by panel manufacturer; designed to provide sufficient movement to prevent creation of points of fixity at penetrations.
- C. Sealant for Field Application: **[high grade non-curing butyl or curing urethane sealant as recommended by panel manufacturer. Do not use sealant containing asphalt.] [See Section 07 92 00 "Joint Sealants".]**

2.7 FABRICATION

- A. Fabrication, General:
 - 1. Unless otherwise shown on Drawings or specified herein, fabricate panels in continuous lengths and fabricate flashings and accessories in longest practical lengths. Contact AEP Span if panel lengths required 77 feet or longer.
 - 2. Panels shall be factory correctively-leveled.
- B. Panels:
 - 1. Provide panels in full length from ridge to eave when possible.
 - 2. Where single length panels are not practical, provide mated swaged panels for positive joint end laps, shingled to accommodate water run-off (fabricated with overlap in direction of water flow).
 - 3. Roof panels shall have flush horizontal and vertical surfaces to facilitate sealing at terminations. Panel configurations which create voids and requiring supplemental closure devices shall not be considered acceptable.
 - 4. Engineer panels to use concealed anchors that permit expansion and contraction, except at eaves, end laps, ridges, valleys, hips and gables.
- C. Seams:
 - 1. Panel seams shall interlock entire length of seam.
 - 2. Design standing seam to lock up and resist joint disengagement during design wind uplift conditions as calculated according to local building codes.
 - 3. Provide pre-installed sealant within confines of panel's female leg to aid in resistance of leaks and provide panel-to-panel seal while allowing expansion and contraction movement.
 - 4. Seams shall be continuously locked or crimped together by mechanical means during installation. Seaming tools shall be sourced from manufacturer's recommended vendor.
- D. Fabrication Tolerances:

See Metal Construction Association Technical Bulletin "Oil Canning" for more information. This bulletin is available at www.aepspan.com.

- 1. Flat metal surfaces will display waviness commonly referred to as "oil canning". This is caused by steel mill tolerances and is a characteristic, not a defect, of panels manufactured from light gauge metal. Panels are factory correctively-leveled to minimize the occurrence of "oil canning". As such, "oil canning" will not be accepted as cause for rejection.

PART 3 - EXECUTION

3.1 EXAMINATION

- A. Verification of Conditions: With Installer present.
 - 1. Examine conditions and substrates on which metal panels are to be installed. Structural support or substrate shall be flat and plumb to avoid panel stresses and distortion.
 - 2. Prior to starting work, correct defects.

- B. Field Measurements:
 - 1. Coordinate field measurements and fabrication schedule with construction progress.
 - 2. Field measure prior to fabrication. Show recorded dimensions on shop drawings, including locations of shop-fabricated openings.
 - 3. If field measurements differ from drawing dimensions, notify Architect prior to fabrication.

- C. **[Framing][Substrate]** Tolerances: Deviations from flat plane shall not exceed the following.
 - 1. 1/4 inch in 20 feet.
 - 2. 1/2 inch across building elevation.
 - 3. 1/8 inch in 5 feet.

3.2 PREPARATION

- A. **[Secondary Framing][Substrate and Underlayment]**: Install according to approved shop drawings and metal panel manufacturer's recommendations.

3.3 INSTALLATION

- A. Panels and Trim: Comply with manufacturer's instructions for assembly, installation and erection for weather tight installation.
 - 1. Install according to approved shop drawings.
 - 2. Install panels in accordance with manufacturer's instructions and recommendations. Anchor securely in place using clips and fasteners spaced in accordance with manufacturer's recommendations for design wind load criteria.
 - 3. Form seams with manufacturer-approved motorized seaming tool; completely engage panel, clip, and factory-applied sealant in seam.
 - 4. Comply with methods and recommendations of SMACNA Architectural Sheet Metal Manual for flashing configurations required.
 - 5. Discrepancies between job site conditions and shop drawings shall be brought to the attention of the Architect for resolution.
 - 6. Cutting and Fitting:
 - a. Cut panels neat, square, and true with shearing action cutters. Torch or power saw cutting is prohibited.
 - b. Openings 6 inches and larger: Shop fabricate and reinforce to maintain original load capacity.
 - c. Openings less than 6 inches: Field cutting is acceptable.
 - 7. Dissimilar Metals or Materials:
 - a. Where panel or trim may come in contact with dissimilar metals or treated lumber, fabricate transition to facilitate drainage and minimize possibility of galvanic action. Galvanic action can cause panels and trim to fail prematurely.
 - b. At points of contact with dissimilar metal or treated lumber, coat panel and trim with protective paint or separate materials with a weatherproof underlayment.
 - c. Direct contact or run-off from CCA, ACQ, CA, or other treated lumber (outdoor wood) or fire retardant impregnated or treated wood shakes or siding can cause panels and trim to fail prematurely. Avoid contact with these materials.

- B. Accessories: Install trims, flashings, and roofing specialties according to Drawings and manufacturer's recommended details.

- C. Sealant Installation: Apply according to approved shop drawings and SMACNA Architectural Sheet Metal Manual recommendations.
 - 1. Provide airtight and waterproof installation.

Generally, retain option in paragraph below and delete subparagraphs. If stringent installation tolerances are required, coordinate with requirements in specifications for framing or substrate to receive panels.

- D. Installation Tolerances: **[Match dimensional tolerances of framing or substrate.]**
 - 1. Flatness: **<Insert requirement.>**

3.4 CLEANING

AEP Span does not recommend touch-up painting of damaged surfaces (minor scratches, etc.) due to fading and weathering differences of the touch-up paints in comparison to factory applied paint systems.

- A. Repairs:
 - 1. Touch up paint is not required for panels with scratches that do not expose metal.
 - 2. Panels or flashings with finish damage exposing metal or with substrate damage shall be replaced.
- B. Cleaning and Waste Management: **[See Division 01 Section "Construction Waste Management and Disposal" for recycling requirements.]**
 - 1. At completion of each day's work and at work completion, sweep panels, flashings, and gutters clean. Do not allow fasteners, cuttings, filings, or scraps to accumulate.
 - 2. Clean exposed surfaces of work promptly after completion of installation.

3.5 PROTECTION

- A. Protect Work as required to ensure that roofing will be without damage at Final Completion.

END OF SECTION

Zincalume® is a registered trademark of BlueScope Steel Ltd.

Hylar 5000® is a registered trademark of Ausimont USA, Inc.

Kynar 500® is a registered trademark of Arkema Inc.

Copyright 2011 by ASC Profiles Inc—a Division of BlueScope Steel. Qualified design and construction professionals may copy for preparation of construction specifications. Issued August 2011.